

TenaControls LLC

Milford, MA 01757 U.S.A.

www.TenaControls.com

TenaControls Brings Models to Life

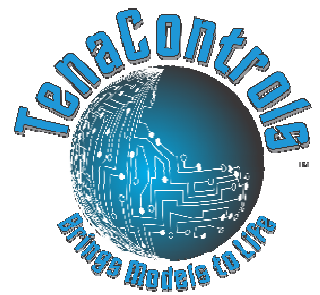

- INSTRUCTIONS -

Instructions of Model# DSCVR-2001 Board. Remote control integrated with a Rear Engine Effect, Cock Pit Lighting, Space Pod Bay Lights and Optional Output for Space Pod Lighting Board for the 2001 Space Odyssey Discovery. Works on any 9 or 12 volt DC power system.

ITEMS YOU WILL NEED:

Soldering Iron

Solder

Cutter

Wire Stripper

****Note:** When using the shrink tubing, you need to only slide the shrink tubing over one leg of the led to keep it from shorting against the other leg. Then use heat gun or flame from lighter to heat the shrink tubing until it shrinks around the wire connected to one of the led legs.

How to distinguish a LED:

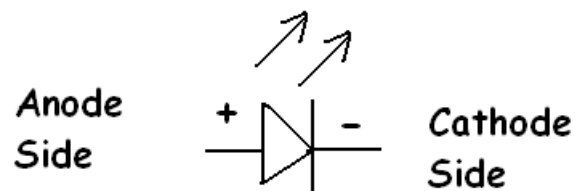
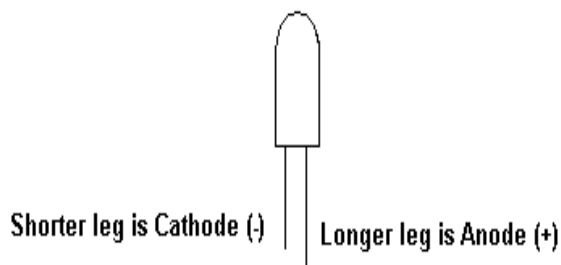

TenaControls LLC

Milford, MA 01757 U.S.A.

www.TenaControls.com

TenaControls Brings Models to Life

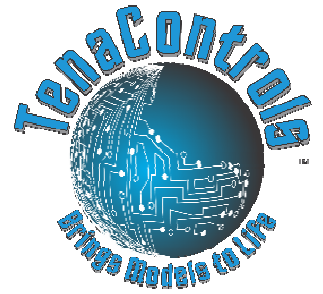

Master Wiring Diagram

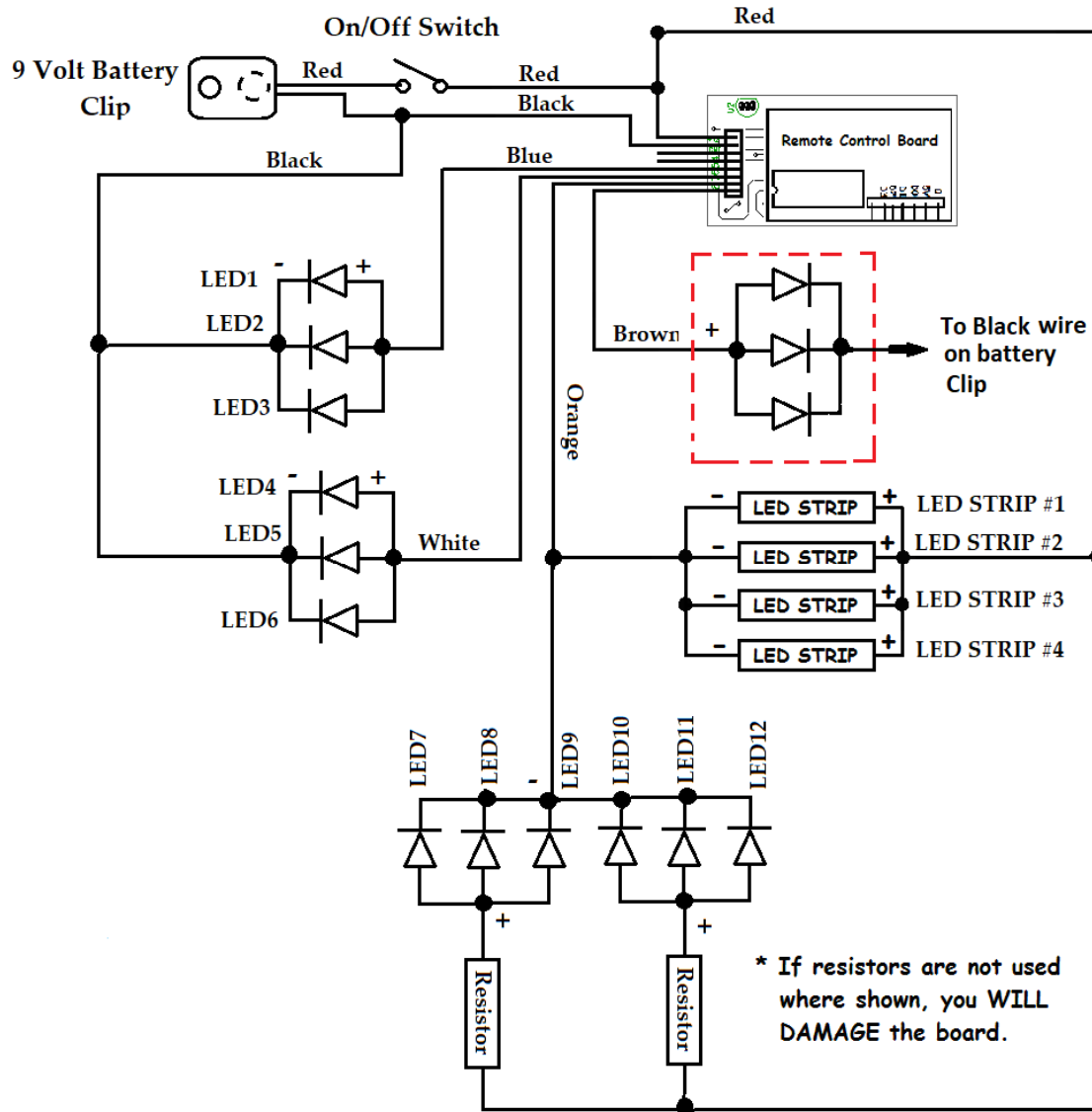

These LED's are NOT included in this kit.

TenaControls LLC

Milford, MA 01757 U.S.A.
www.TenaControls.com

TenaControls Brings Models to Life

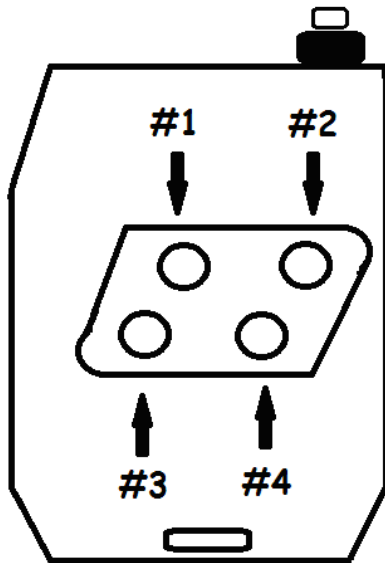

Transmitter FOB's will come in one of two types. Buttons 2-4 are located differently.

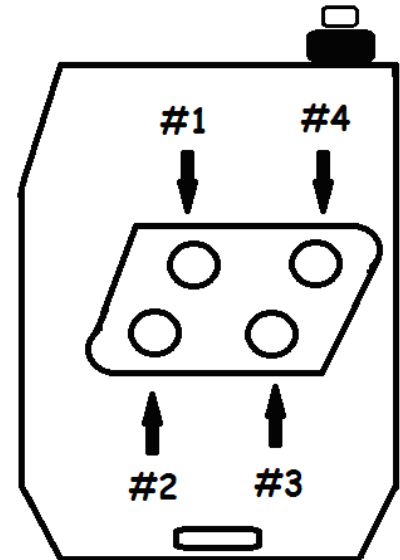

Some Manufacturers mark Output #1 = Marked A or C

Some Manufacturers mark Output #2 = Marked A or B

Some Manufacturers mark Output #3 = Marked C or D

Some Manufacturers mark Output #4 = Marked B or D

TenaControls LLC

Milford, MA 01757 U.S.A.
www.TenaControls.com



TenaControls Brings Models to Life

Engine Lights Bank One

1. LED1-LED3, the Three Cathodes (-) of the White 0805 SMD LED's, connect to the Black wire on mating connector. Then connect the Anodes (+) of LED1-LED3 to Blue wire on mating connector. Use Button A to activate and de-activate. First press starts the ramp up to full Engine effect, second press turns to static on, third press starts the ramp down to off. **See above diagram.**

Engine Lights Bank Two

2. LED4-LED6, the Three Cathodes (-) of the White 0805 SMD LED's, connect to the Black wire on mating connector. Then connect the Anodes (+) of LED4-LED6 to White wire on mating connector. Use Button A to activate and de-activate. First press starts the ramp up to full Engine effect, second press turns to static on, third press starts the ramp down to off. **See above diagram.**

Cock Pit Lights

3. LED7-LED9, For control Panels Locations. The Three Cathodes (-) of the Warm White 0805 SMD LED's, connect to the Orange wire on mating connector. Then connect the Anodes (+) of LED7-LED9 to one end of Resistor and the other end of Resistor to Red wire on mating connector. Ceiling LED Strip #1 is the Cool White. Connect the Minus side to the Orange wire on mating connector and Positive Side connects to Red wire on mating connector. Use Button B to activate and de-activate **See above diagram.**

Space Pod Bay Lights

4. LED10-LED12, For Side Wall Back Lights. The Three Cathodes (-) of the Warm White 0805 SMD LED's, connect to the Orange wire on mating connector. Then connect the Anodes (+) of LED10-LED12 to one end of Resistor and the other end of Resistor to Red wire on mating connector. Ceilings, LED Strip # 2-4 are the Cool White. Connect the Minus side to the Orange wire on mating connector and Positive Side connects to Red wire on mating connector. Use Button B to activate and de-activate **See above diagram.**

Optional Space Pod Lights

5. The Three optional SMD or One 5 mm LED and Fiber Optic Strands are **not supplied by TenaControls.** We do provide a output for this function, Use Button C to activate and de-activate. **See above diagram.**

TenaControls LLC

Milford, MA 01757 U.S.A.

www.TenaControls.com

TenaControls Brings Models to Life



Warranty

TenaControls LLC warrants that the control boards sold meet TenaControls LLC specifications and are adequately contained, packaged and labeled and conform to the promises and affirmations of fact made on the container and label. THE FOREGOING WARRANTIES ARE EXCLUSIVE, AND ARE IN LIEU OF ALL OTHER WARRANTIES (WHETHER WRITTEN, ORAL OR IMPLIED) INCLUDING WARRANTY OR MERCHANTABILITY IN OTHER RESPECTS THAN EXPRESSLY SET FORTH ABOVE AND WARRANTY OF FITNESS FOR A PARTICULAR PURPOSE.

In the event that there is a breach of express warranty by the manufacturer made in connection with the purchase of this product, if any, the sole remedy of any buyer shall be to return the product along with original sales receipt, at **buyer's expense** for repair (or replacement of the product if repair is impossible) to the manufacturer's facility in the Commonwealth of Massachusetts, located at 22 Hancock Street, Milford, MA 01757. Some states do not allow the exclusion or limitation of any incidental or consequential damages, so the above limitation may not apply to you. Nothing herein contained shall be construed to be a waiver by the manufacturer of any of the obligations imposed upon said buyer under the laws of the Commonwealth of Massachusetts except as herein specifically stated.

This warranty is enforceable only by the buyer of the product or a person in the buyer's immediate family. This warranty is enforceable for a period of **FIVE YEARS** from the date of purchase. Some states do not allow limitations on how long an implied warranty lasts, so the above warranty may not apply to you. This warranty gives you specific legal rights and you may also have other rights which vary from state to state.

Warranty Void if:

- A) Product is altered in any way.
- B) Used for other than its intended use.
- C) Buyer mishandling.